

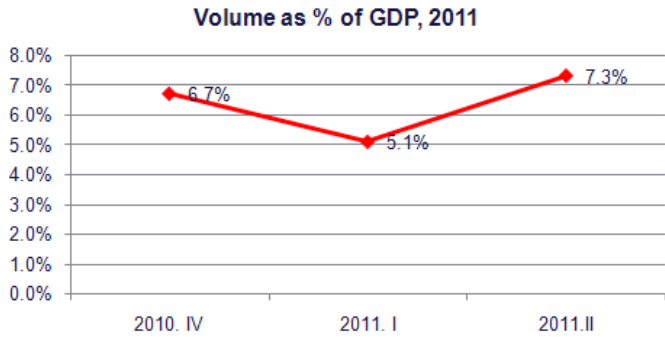

# Luxoft Financial Services

**Virtual Data Room — Technology  
behind M&A transactions in financial  
industry**

# M&A Market in Russia

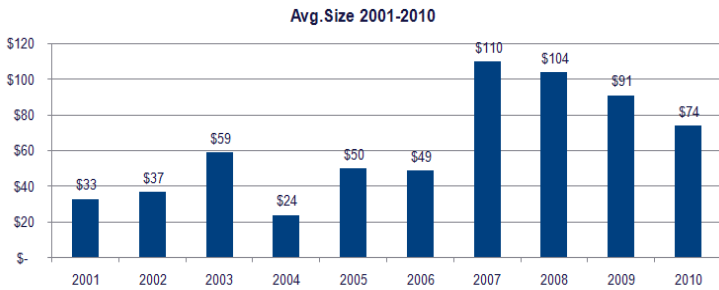
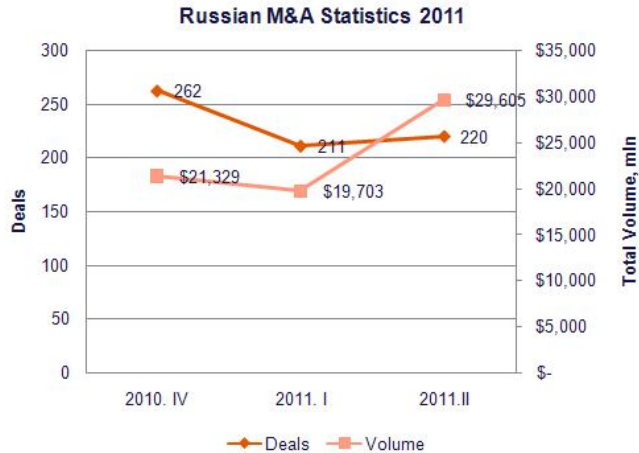

Source: <http://www.mergers.ru>

# IPO Market in Russia



Russian IPO Statistics



Avg. Size

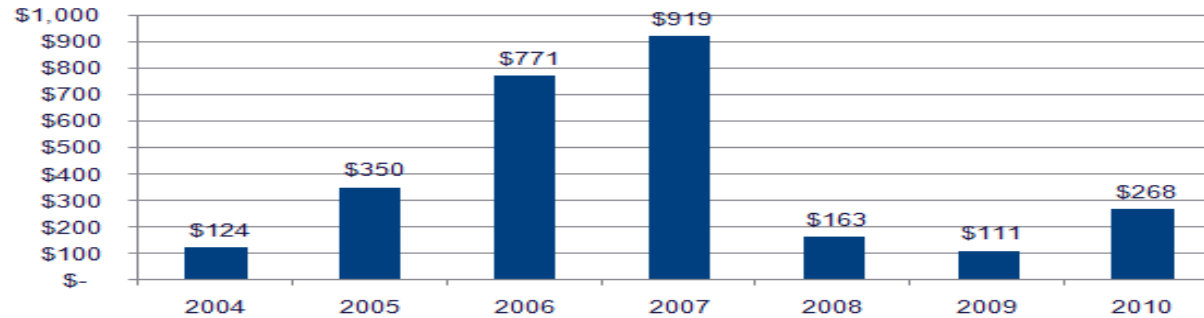

Volume as % of GDP

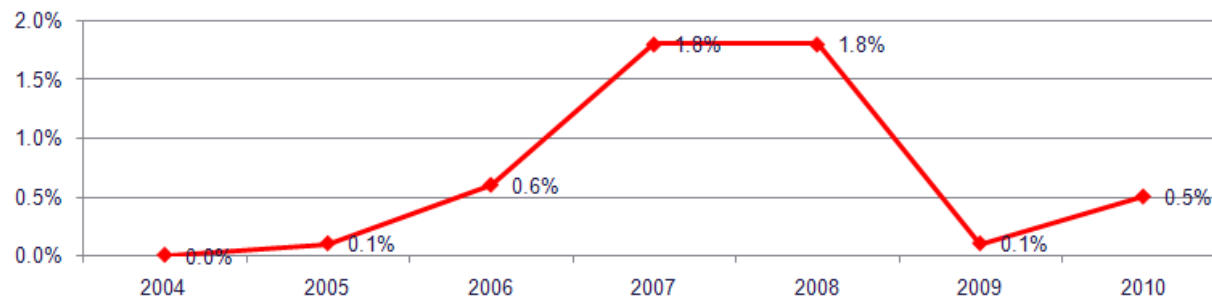

Source: <http://www.offerings.ru>

# Due-Diligence in M&A Process

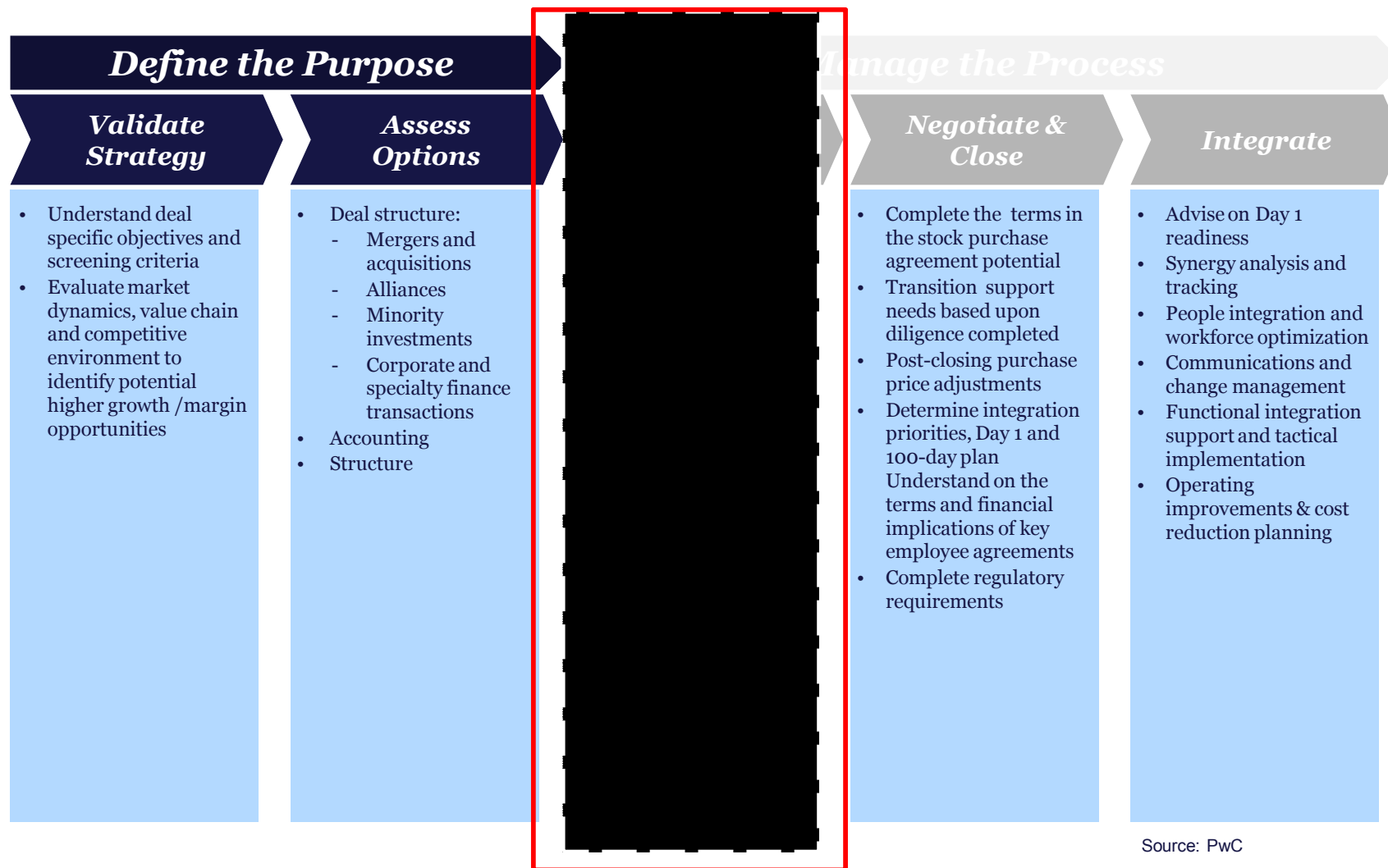

Source: PwC

# Types of Due-Diligence

- Commercial
- Operational
- IT
- Environmental
- HR
- Legal
- Tax
- Financial
  - Historic performance
  - Projections

***Due diligence***  
the process through which a potential acquirer evaluates a target company for acquisition (Wikipedia)



# System Users

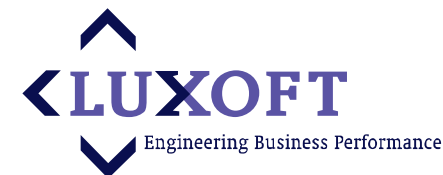

- Bidder side
  - Lawyer and Bankers advising one of the Bidder companies
  - Middle Management Bankers, Analysts and Financial Advisers
  - Senior Partners of Law Firm, Company Board Members, Senior Executives
- Sell Side – Deal Admin
  - Lawyers and Paralegals
  - Senior Legal and Financial Advisers, and client company executives
- VDR Platform Staff
  - VDR Sales
  - VDR User Support
  - VDR Admins

# Index

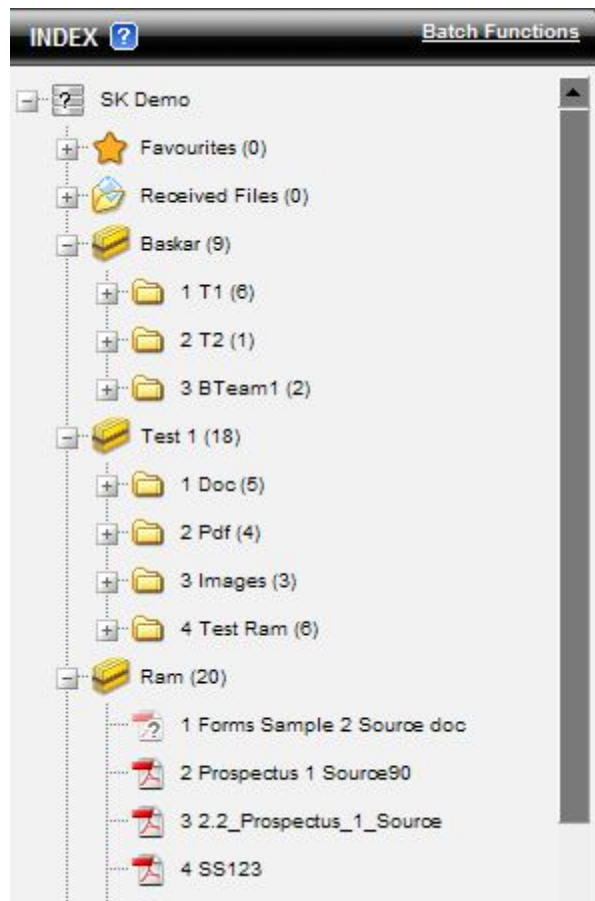

- Structured collection of documents and relevant materials (including pictures, scans, videos and sound clips)
- Structured to serve Due-Diligence purposes: separate financial, legal, historical, marketing, etc. groups of documents
- Specifically numbered for convenience purposes

# Index Preparation

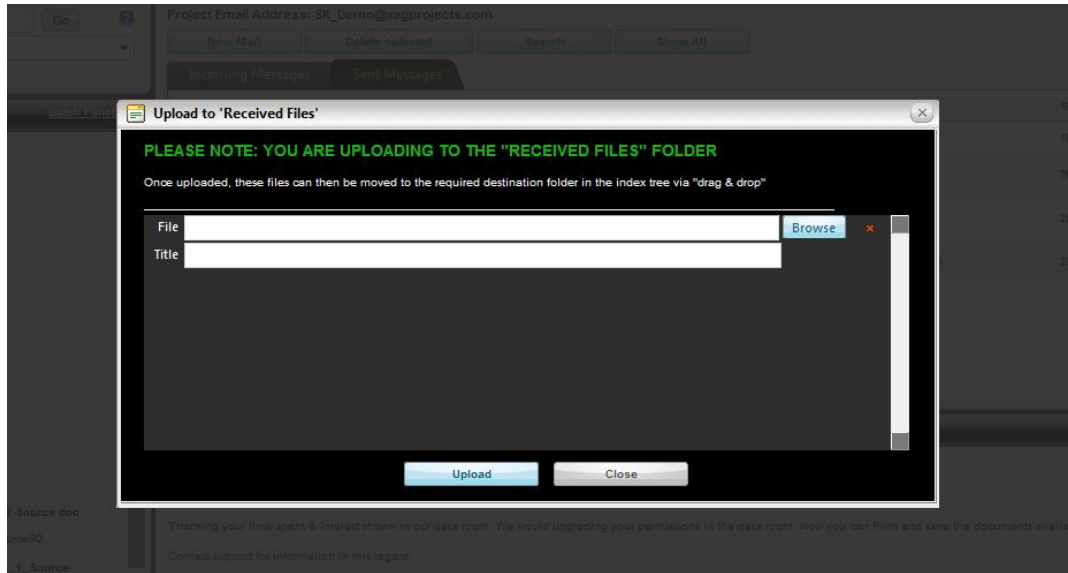

- One-by-one upload
- Batch loading

Automatically installed browser plug-in for batch operations:

- Initial structure creation
- Structure update (document movements)



# Document Permissions

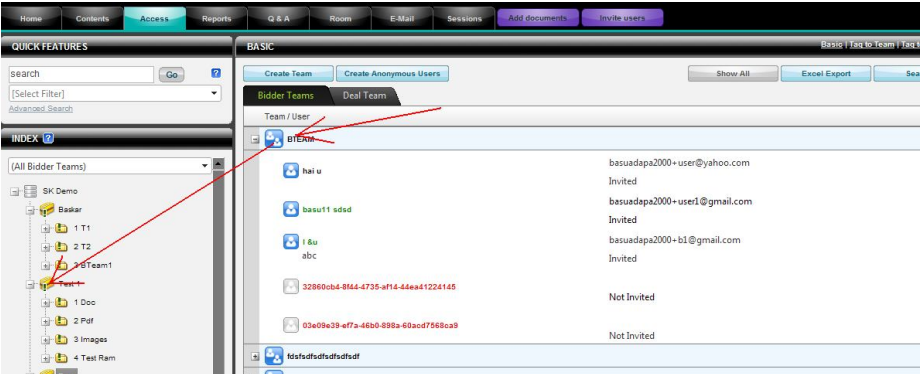

Drag-and-drop Bidder or Seller Teams

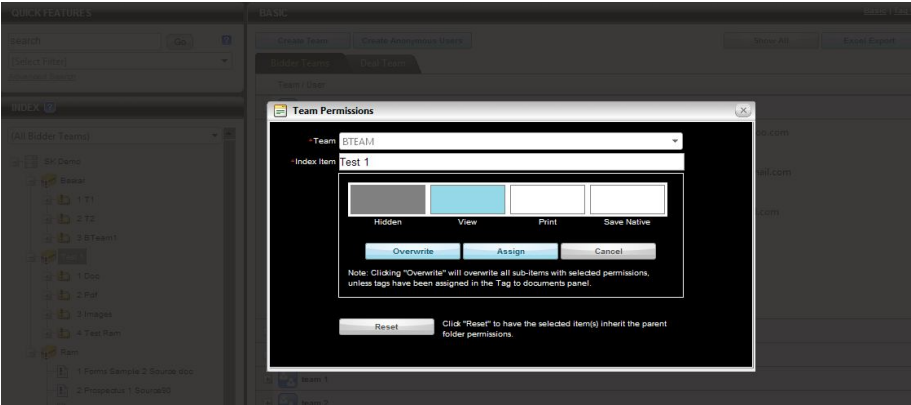

Permissions:

- Hide
- View
- Print
- View Native

Complex inheritable permissions, including negative permissions. Special database logic to handle permissions calculation.

# Full Text Search

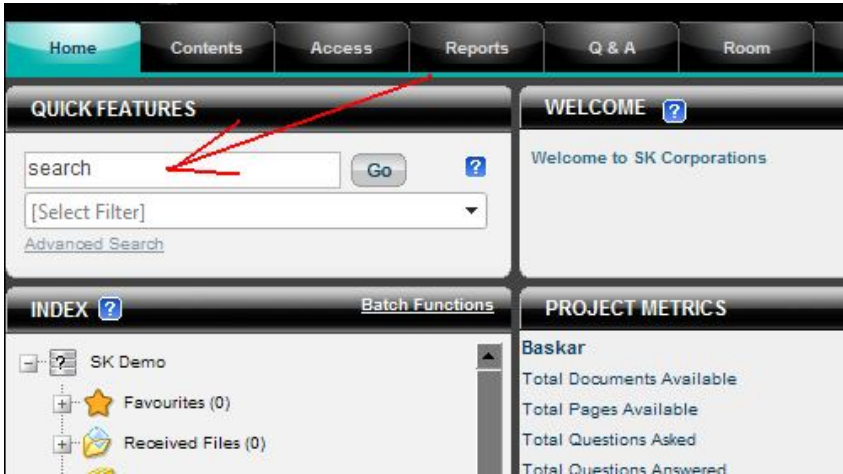

Uses MS SQL Full Text Search

Searches in all document types, including PDFs

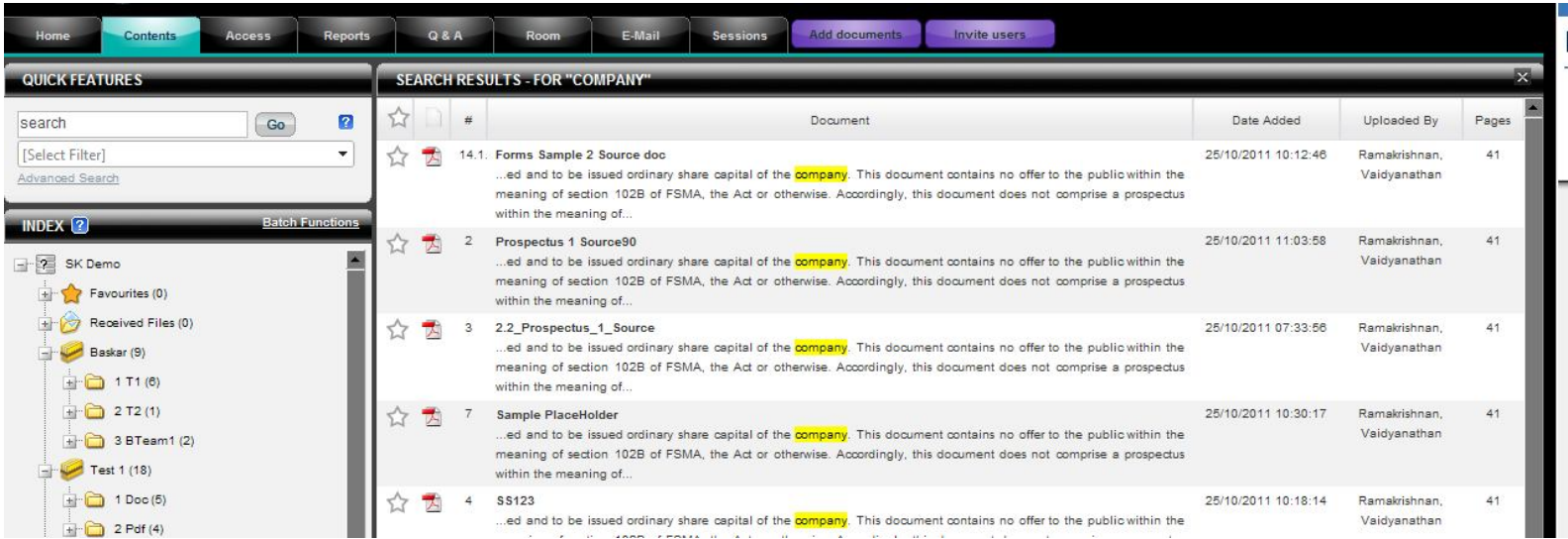

# Reporting

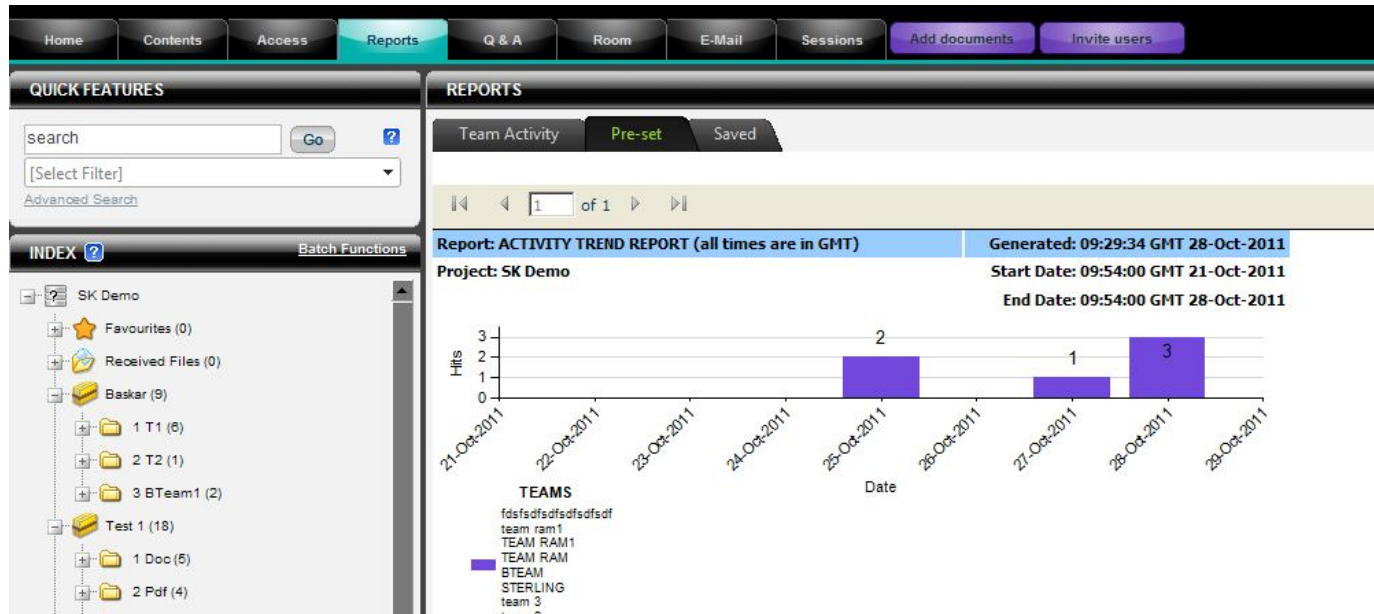

MS Reporting Services

Preset and Customized Reports

- Track the Due-Diligence progress
- Track the per team and per document activities

# Dashboard



The dashboard is divided into several sections:

- QUICK FEATURES:** Includes a search bar and a filter dropdown.
- WELCOME:** Displays a welcome message for 'SK Corporations'.
- DEAL MANAGER:** Shows contact details for 'Main Contact: Aloysius Sharma, xxxx'.
- INDEX:** A tree view showing project structure with folders like 'Favourites (0)', 'Received Files (0)', 'Baskar (0)', '1 T1 (6)', '2 T2 (1)', '3 BTeam1 (2)', 'Test 1 (18)', '1 Doc (6)', '2 Pdf (4)', '3 Images (3)', '4 Test Ram (6)', and 'Ram (20)'. A sub-item '1 Forms Sample 2 Source doc' is visible under 'Ram'.
- PROJECT METRICS:** A table showing metrics for 'Baskar' and 'Ram'.

Metric	Baskar	Ram
Total Documents Available	9	20
Total Pages Available	92	
Total Questions Asked	7	
Total Questions Answered	7	
- NEW Q&A ACTIVITY SINCE LAST LOGIN:** A table with columns 'ID', 'Question', 'Status', and 'Team'. It shows 'No records to display.'
- USER ACTIVITY (PAST 24 HOURS):** A table with a central box stating 'No data to display.'
- OPEN EDIT SESSION:** A table with columns 'Session Owner', 'Owner Full Name', and 'Started At'.

Session Owner	Owner Full Name	Started At
kvkr82zdealadmin@gmail.com	Ramakrishnan Vaidyanathan	09:57:28/10/2011
Ramakrishnan@sterlingrag.com	Ramakrishnan Vaidyanathan	09:51:28/10/2011

- At a glance Due-Diligence project overview
- Available for every Deal participant with appropriate permissions
- Customizable per user and per project

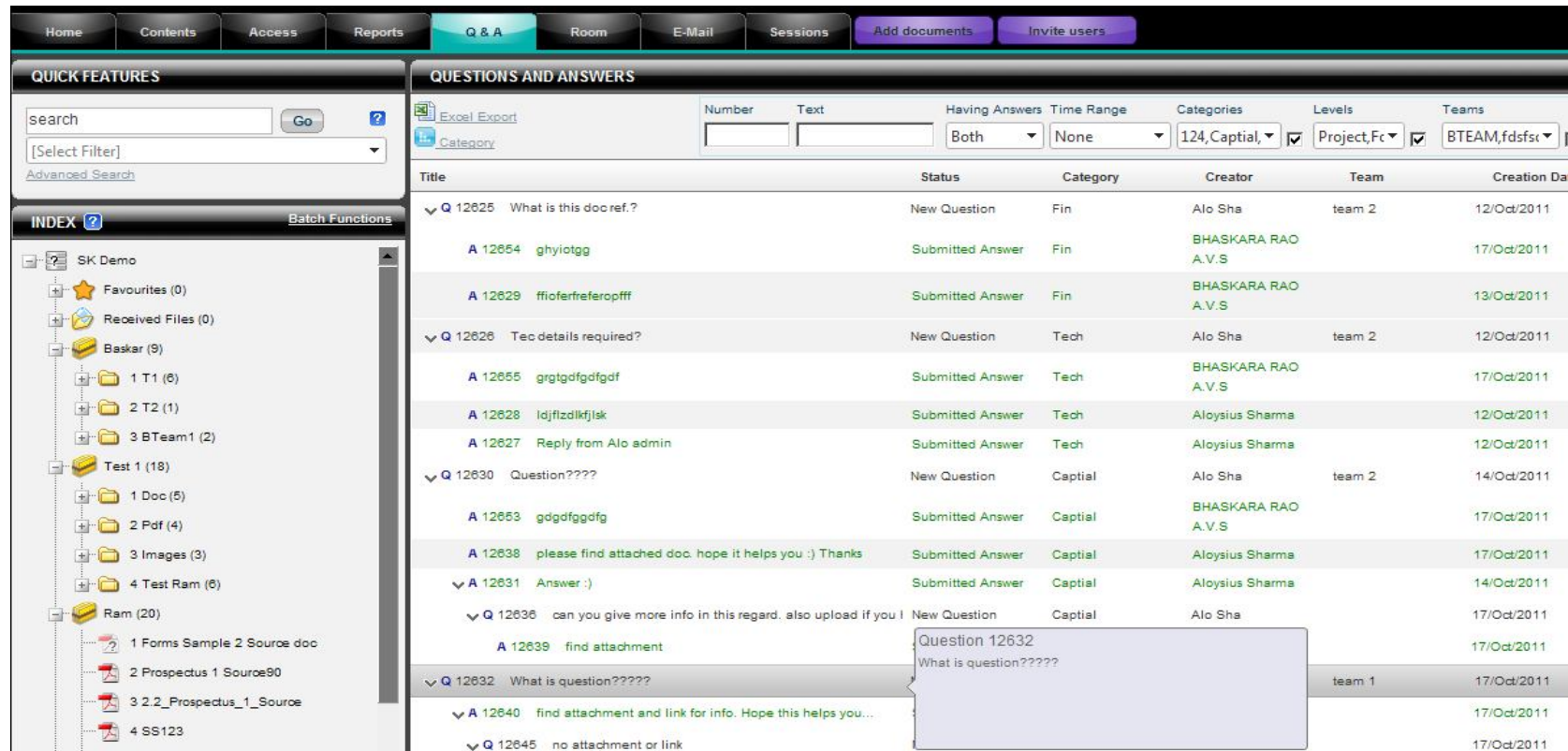

The screenshot displays the Q&A application interface. At the top, there is a navigation bar with tabs for Home, Contents, Access, Reports, Q & A (active), Room, E-Mail, and Sessions. Below the navigation bar, there are buttons for 'Add documents' and 'Invite users'.

The main interface is divided into two main sections:

- QUICK FEATURES:** Includes a search bar with a 'Go' button and a '[Select Filter]' dropdown menu. Below it is an 'Advanced Search' link.
- INDEX:** A tree view showing a folder structure. The root is 'SK Demo', which contains several sub-folders and files:
  - Favourites (0)
  - Received Files (0)
  - Baskar (9)
    - 1 T1 (6)
    - 2 T2 (1)
    - 3 BTeam1 (2)
  - Test 1 (18)
    - 1 Doc (5)
    - 2 Pdf (4)
    - 3 Images (3)
    - 4 Test Ram (6)
  - Ram (20)
    - 1 Forms Sample 2 Source doc
    - 2 Prospectus 1 Source90
    - 3 2.2\_Prospectus\_1\_Source
    - 4 SS123

- QUESTIONS AND ANSWERS:** A table listing questions and answers. The table has columns for Title, Status, Category, Creator, Team, and Creation Date. The data is as follows:
 

Title	Status	Category	Creator	Team	Creation Date
Q 12625 What is this doc ref.?	New Question	Fin	Alo Sha	team 2	12/Oct/2011
A 12654 ghyiotgg	Submitted Answer	Fin	BHASKARA RAO A.V.S		17/Oct/2011
A 12629 ffioferferferopfff	Submitted Answer	Fin	BHASKARA RAO A.V.S		13/Oct/2011
Q 12626 Tec details required?	New Question	Tech	Alo Sha	team 2	12/Oct/2011
A 12655 grgtdfgdgdgdf	Submitted Answer	Tech	BHASKARA RAO A.V.S		17/Oct/2011
A 12628 ldjflzdlkfljlsk	Submitted Answer	Tech	Aloysius Sharma		12/Oct/2011
A 12627 Reply from Alo admin	Submitted Answer	Tech	Aloysius Sharma		12/Oct/2011
Q 12630 Question?????	New Question	Captial	Alo Sha	team 2	14/Oct/2011
A 12653 gdgdgfgdgdg	Submitted Answer	Captial	BHASKARA RAO A.V.S		17/Oct/2011
A 12638 please find attached doc. hope it helps you :) Thanks	Submitted Answer	Captial	Aloysius Sharma		17/Oct/2011
A 12631 Answer :)	Submitted Answer	Captial	Aloysius Sharma		14/Oct/2011
Q 12636 can you give more info in this regard. also upload if you l	New Question	Captial	Alo Sha		17/Oct/2011
A 12639 find attachment	Submitted Answer				17/Oct/2011
Q 12632 What is question?????	New Question			team 1	17/Oct/2011
A 12640 find attachment and link for info. Hope this helps you...	Submitted Answer				17/Oct/2011
Q 12645 no attachment or link	New Question				17/Oct/2011

- Per any Index Item
- Thread-like Structure
- Can contain attachments and links to other documents

# Emailing

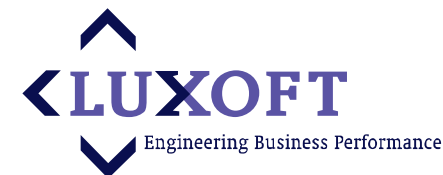

The screenshot displays a web-based email interface. At the top, there is a navigation bar with tabs for Home, Contents, Access, Reports, Q & A, Room, E-Mail (selected), Sessions, Add documents, and Invite users. Below the navigation bar, the interface is divided into several sections:

- QUICK FEATURES:** Includes a search bar with a "Go" button and a "[Select Filter]" dropdown menu.
- INDEX:** A tree view showing a project structure for "SK Demo". It includes folders like "Favourites (0)", "Received Files (0)", "Baskar (9)", "Test 1 (18)", and "Ram (20)". Under "Test 1", there are sub-folders for "Doc (5)", "Pdf (4)", "Images (3)", and "Test Ram (6)". Under "Ram", there are files like "1 Forms Sample 2 Source doc", "2 Prospectus 1 Source90", "3 2.2\_Prospectus\_1\_Source", "4 SS123", "5 Aloysius CSE signed", and "6 convection\_issues".
- EMAIL:** Shows the "Project Email Address: SK\_Demo@xagprojects.com". It has buttons for "New Mail", "Delete selected", "Search", and "Show All". Below this, there are tabs for "Incoming Messages" and "Sent Messages". A table of sent messages is displayed:

<input type="checkbox"/>	Subject	To	From	Sent
<input type="checkbox"/>	Thank You	A S	meetalloysius@gmail.com	18/10/2011 08:03:03
<input type="checkbox"/>	BHASKARA RAO A.V.S has shared a document on SK Demo data room	basuadapa2000+user1@yahoo.com	BHASKARA	20/10/2011 05:55:04
<input type="checkbox"/>	BHASKARA RAO A.V.S has shared a document on SK Demo data room	basuadapa2000+user1@yahoo.com	BHASKARA	20/10/2011 08:03:02
<input type="checkbox"/>	Ramakrishnan Vaidyanathan has shared a document on SK Demo data room	Ramakrishnan Vaidyanathan	Ramakrishnan@sterlingxag.com	27/10/2011 07:47:20

Below the table, there is a "THANK YOU" section with the following text:

Good morning.  
Greetings SK Corporation.  
Thanking your time spent & interest shown in our data room. We would upgrading your permissions in the data room. Now you can Print and save the documents available in your view.  
Contact support for information in this regard.  
Thank you,  
Aloysius

Secure and consolidated Due-Diligence project related emailing

# User Profile Maintenance



**Profile - haverha**

Global (These are settings for that apply globally across all projects)

\*UserName   Help Overlay Enabled

\*Email  \*Confirm Email

\*First Name  \*Last Name

\*Mobile Phone  Desk Phone

Function

Country

Address

Security Question List

Custom Question

Security Answer

Note: leave answer blank for reusing old answer, question and username.

Free Text

OK

Password

\*Old Password

\*New Password  \*Confirm New Password

OK

Project Settings (These are settings specific for this project only)

Post Notification Type   Show document count

Manage Dashboard View

<input checked="" type="checkbox"/> Project Metrics	<input checked="" type="checkbox"/> New Q&A Activity Since Last Login	<input checked="" type="checkbox"/> User Activity (Past 24 Hours)
<input type="checkbox"/> New Documents Since Last Log-In	<input type="checkbox"/> Document Conversion Issues	<input checked="" type="checkbox"/> Open Edit Session
<input type="checkbox"/> Most Popular Documents		

OK

Browser Check

- General user information maintenance
- Dashboard settings
- Global and per Project





# Secure Document View

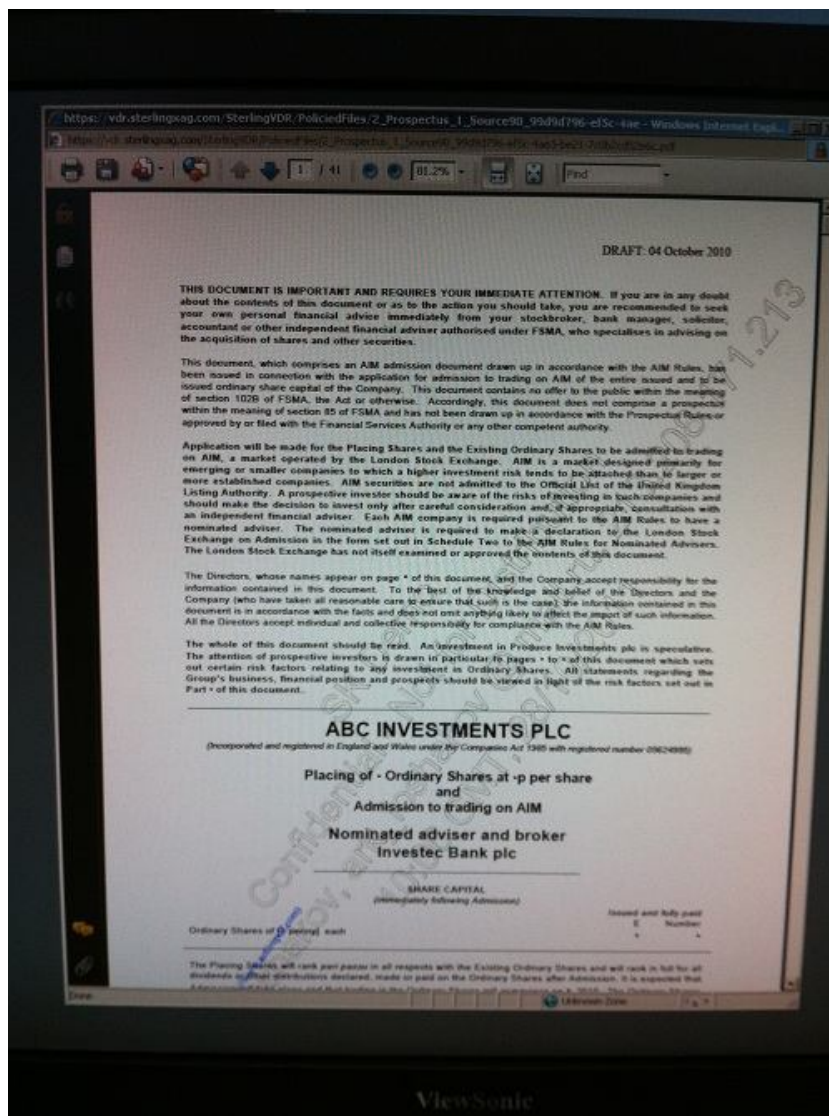

- No Extra Plug-In necessary (uses PDF Acrobat Reader)
- Secure Watermark with current user and IP address
- No ability to save or print
- No ability to screen-shot

# Working with Index Items

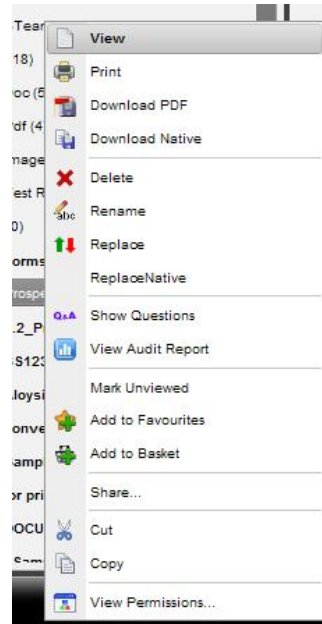
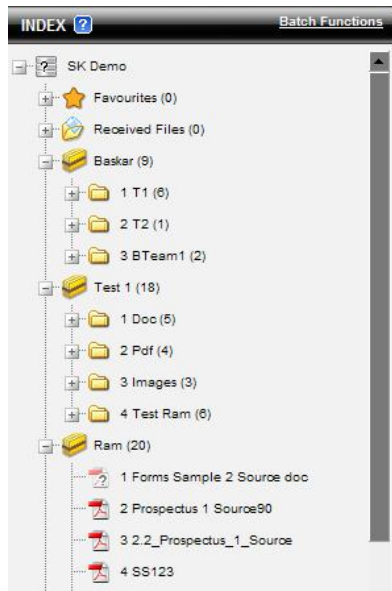

- Secure View
- Print or Download
- Download Native
- Q&A Integration
- Bulk operations (Basket)
- Secure Sharing

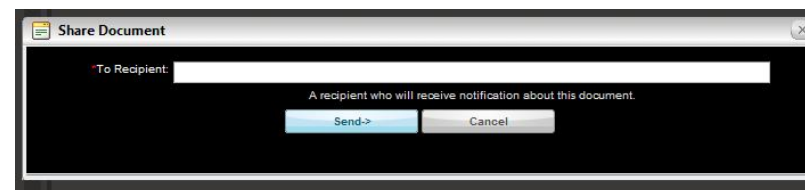

# Online Help

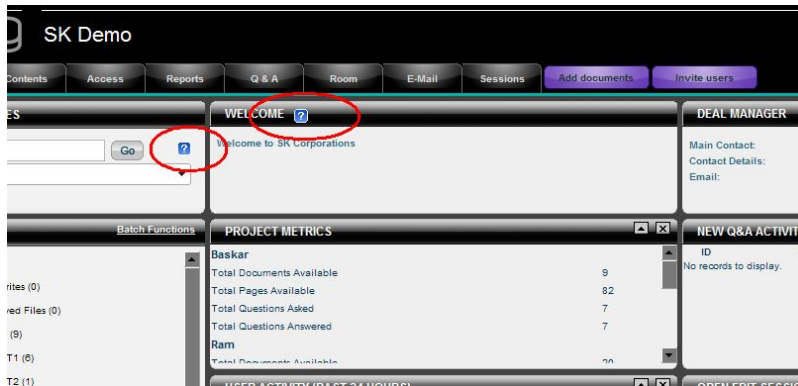

- Comprehensive set of tooltips
- Can be turned on/off

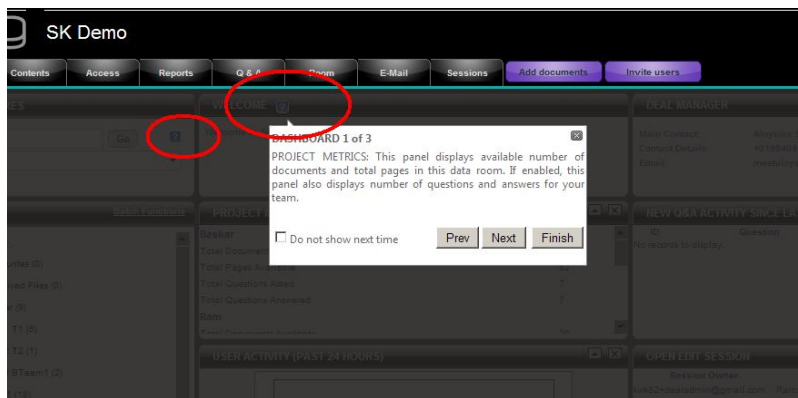

# Deal Room Features Management



The screenshot displays the 'Room Settings' configuration page for a project named 'SK Demo'. The interface includes a navigation bar at the top with tabs for Home, Contents, Access, Reports, Q & A, Room (active), E-Mail, Sessions, Add documents, and Invite users. Below the navigation bar, the 'PROJECT STATUS' section shows 'Current Status: Live' with buttons for Lock, Close, Revert, and Download Contract, along with a 'Sign Date: 11/10/2011'. The 'Room Settings' section is divided into several panels: 'Room Settings' (Project Name: SK Demo, Project Code: SKD, Email: SK\_Demo@xagprojects, Company Name: SK Corp, Project Manager: Senthil Kumar, Sales Person: SK, Expiration Date: 25/10/2011, Welcome Text: Welcome to SK Corporations), 'Billing Features' (SMS PIN Authentication, Digital Rights Management, Watermark, Extended Print, PDF Conversion, OCR Conversion, Page Preview, Anonymous User Creation, Email-in Files, Custom Logo, Q&A Enabled, Full Text Search Enabled, Advanced Search, User Approval, Deal Manager Panel, Auto Commit, E-Mail Tab, Reports Tab), 'Registered Q&A' (Simple, Advanced), 'Advanced Print Settings' (Copy for Print Disabled, Allow Copy for Print), 'Billing Type' (Documents, Pages, Physical Space), 'Room Type' (Live Deal, Personal, Demo, Corporate Communications, Investor Communications), and 'Limits' (Allowed Size (Mb): 100, Number of Documents: 0, Number of Users: 100). A 'Save' button is located at the bottom of the settings panel.

## Billing types:

- Per Document
- Per Size
- Per Users

- Additional SMS Authentication
- DRM On/Off
- Watermark
- Extended Printing
- PDF Conversion
- OCR Conversion
- Quick Preview
- Documents Mail-In
- Q&A
- Advanced Search
- Size and Documents limits

# Deal Room Maintenance



Home Contents Access Reports Q & A Room E-Mail Sessions Add documents Invite users

**PROJECT STATUS**

Current Status: Live [Lock](#) [Close](#) [Revert](#) [Download Contract](#) Sign Date: 11/10/2011

Room Settings Setup Q&A Custom Archiving Scheduled Events Templates

The full archive was created.

Document Version

Only PDF

PDF and Original Files

Apply Watermark

Content Management

Reporting Data

Q&A Data

Archive Type

Overall

Bidder Select Groups: BTEAM

[Archive](#)

- Archiving
- Event Scheduling:
  - Auto invitation send
  - Deal expiration

Home Contents Access Reports Q & A Room E-Mail Sessions Add documents Invite users

**PROJECT STATUS**

Current Status: Live [Lock](#) [Close](#) [Revert](#) [Download Contract](#) Sign Date: 11/10/2011

Room Settings Setup Q&A Custom Archiving Scheduled Events Templates

[Filter](#) [Reset](#) [Add](#)

Id	Description	Type	Status	Scheduled On	Handled On
375	Invitation for meetaloyusius+user4@gmail.com	Invitation	Handled	13/10/2011 06:00:00	13/10/2011 06:00:09
374	SK Demo will expire after 25/10/2011 06:17:38	Expiration Alert	Handled	18/10/2011 06:17:38	18/10/2011 06:17:46

# Index Modification Transaction Support

A screenshot of the LUXOFT web application interface. The top navigation bar includes links for Home, Contents, Access, Reports, Q & A, Room, E-Mail, Sessions, Add documents, and Invite users. The 'Sessions' tab is active. On the left, there is a 'QUICK FEATURES' sidebar with a search box, a filter dropdown, and an 'Advanced Search' link. The main content area is titled 'SESSIONS' and contains a table with columns for 'Started At', 'Session Owner', and 'Owner Full Name'. Two rows of data are visible, both with a 'Pending Changes' button next to the 'Started At' column.

	Started At	Session Owner	Owner Full Name
<a href="#">Pending Changes</a>	09:57 28/10/2011	kvrk82+dealadmin@gmail.com	Ramakrishnan Vaidyanathan
<a href="#">Pending Changes</a>	09:51 28/10/2011	Ramakrishnan@sterlingxag.com	Ramakrishnan Vaidyanathan

- Ability to prepare Index modification first (no-one else sees the modifications before Session commit)
- Ability to double check and review changes before commit
- Atomic Session commit
- Changes Rollback support

# Deal Participants Invitation



- User receives an automatic email with a link to a Data Room
- System tracks those invitations sent and subsequent user registrations and logins
- Support for anonymous users (only email, can also be public email)
- Scheduled/Delayed invitation support

# Bulk Operations Support

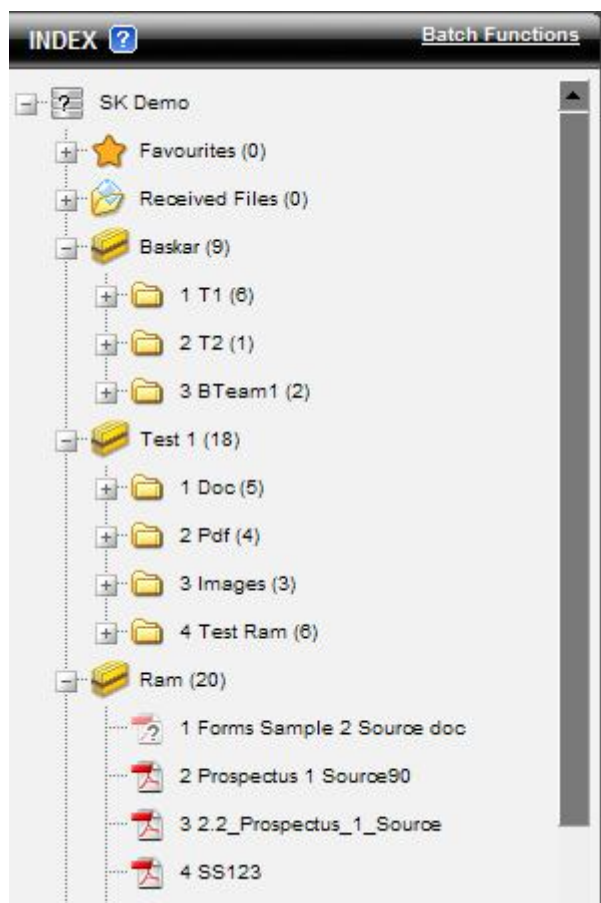
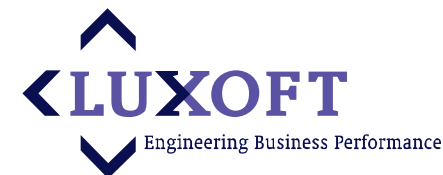

- Initial Index Preparation
- Index Modifications (including atomic commits)
- Document Printing
- Bulk Download

Uses Installable Plug-In (SSO supported)



# Document Conversion



- Only PDF format is supported by Adobe Reader (to apply Watermarks and DRM)
- Hence all documents should be converted to PDF (Excel, Word, JPG, PNG, etc.)
- OCR is used to provide Full-Text search feature for Scanned Documents and PDFs

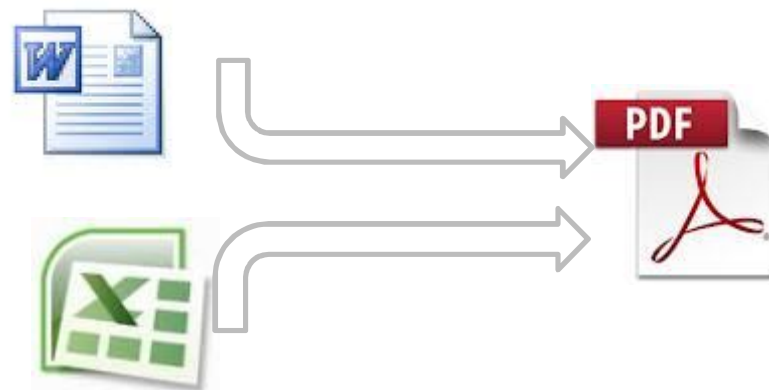

# DRM Application

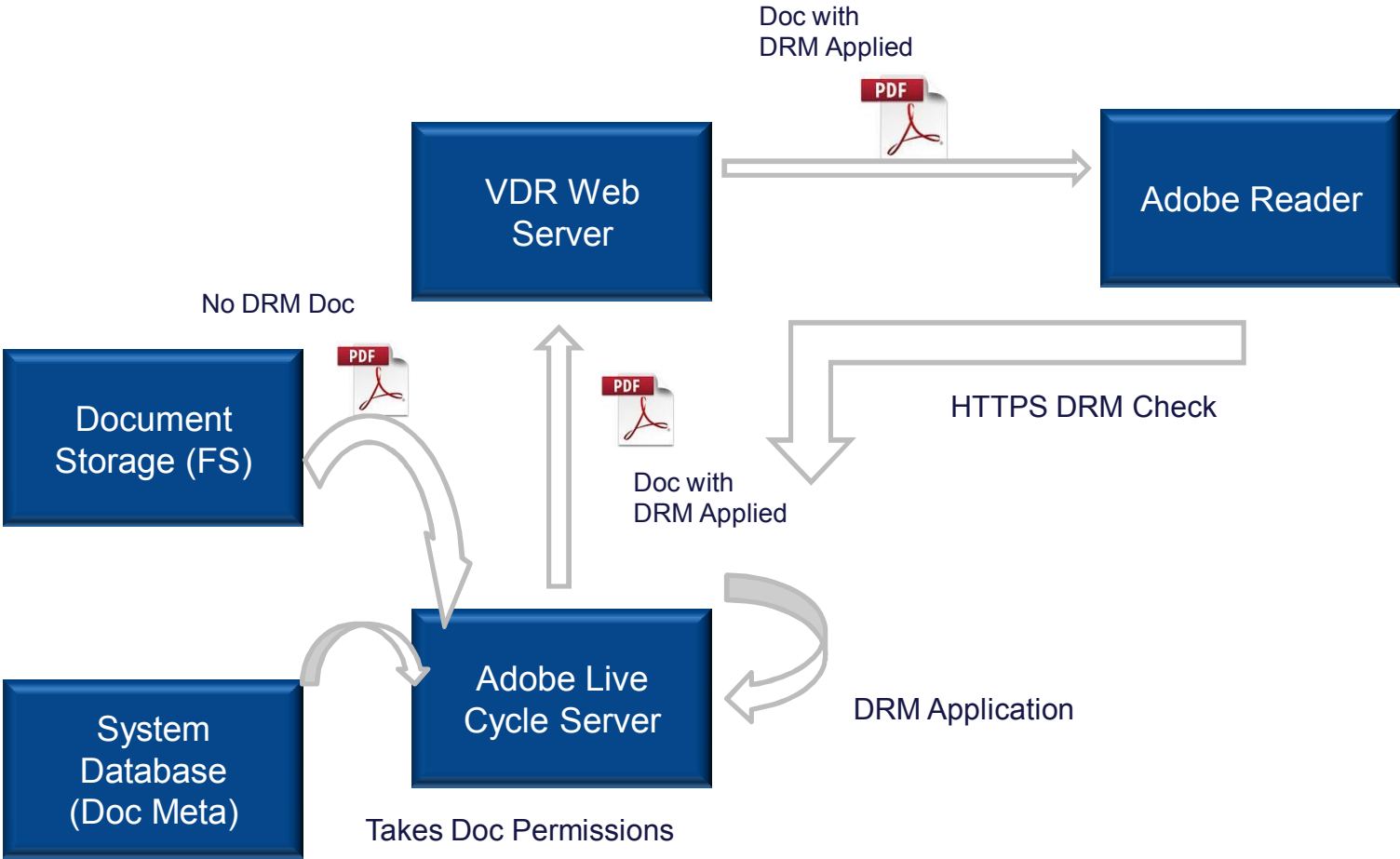
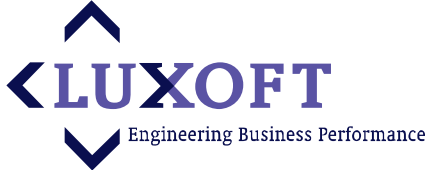

# VDR Services

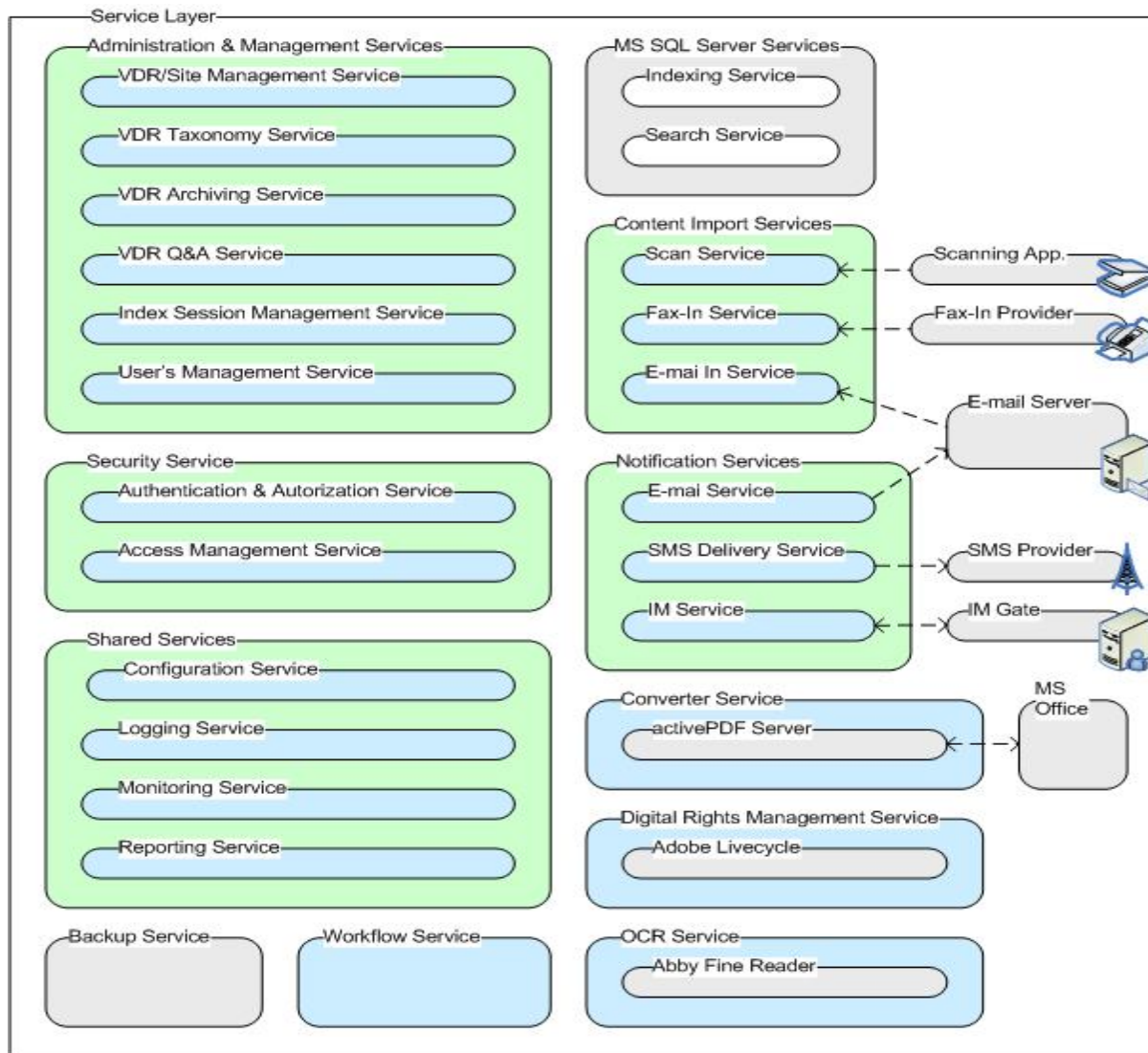
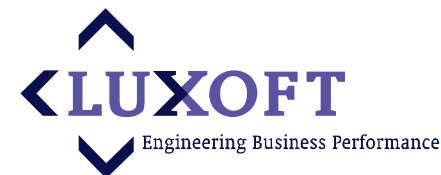

# Logical System Deployment

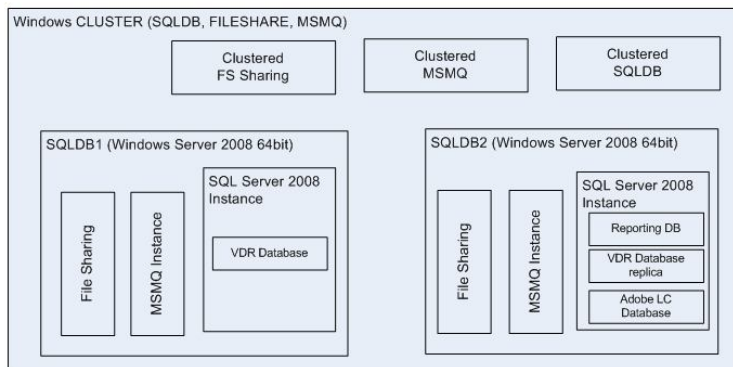
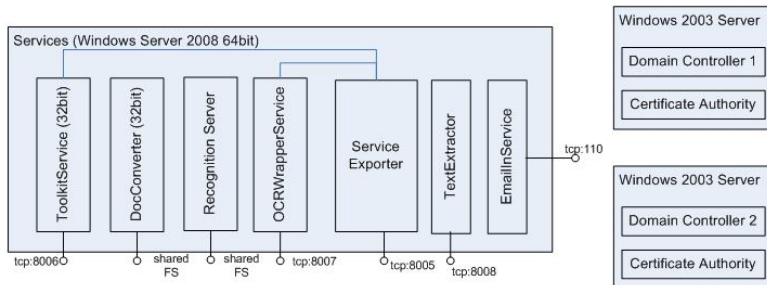
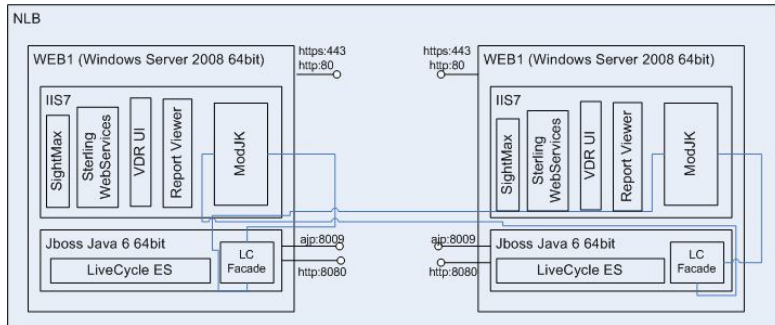

Physical Storage

- Windows 2008 Server
- Adobe LiveCycle ES running on Tomcat and Java
- Network Load Balancing Service
- Dedicated Services Box
- MS SQL 2008 Database Cluster
- Dedicated Reporting Database
- Clustered MSMQ

## Project Facts

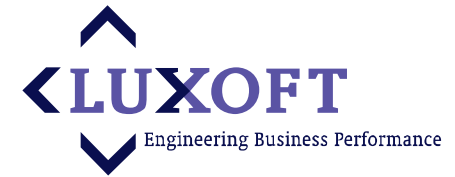

- 26,000 Man-hours to build
- 27 People at Peak
- Distributed cross location team (Moscow, London, Omsk, Vietnam)
- Duration 8 months
- Live in Prod since Oct 2009
- Over 500 users
- 24x7 System availability and support

Thank You!